



Tsunami

SPORT/PRO

WATERS

the essence of health & fitness

INDOOR CYCLE OWNER'S MANUAL

Thank you for choosing WATERS FITNESS to assist you in meeting your fitness goals. The information in this manual will help you with the assembly, operation and maintenance of your WATERS FITNESS Indoor Cycle.

Please review this Owner's Manual carefully before you use your Indoor Cycle. As always, please check with your physician before beginning any exercise program. Your new Indoor Cycle is designed to provide active aerobic exercise, so it is possible to over-exert yourself. If you experience chest pains, feel faint, dizzy or have shortness of breath, stop exercising and immediately consult a physician.

If you have any questions or require service on your Indoor Cycle, your professional WATERS FITNESS Retailer would be more than happy to assist you. Should your issue require more assistance than your WATERS FITNESS Retailer can provide, please contact us for further assistance.

WATERS

the essence of health & fitness

Warranty

WATERS FITNESS warrants to the original owner that our products will be free of all defects in materials and workmanship.

Frame - 10 years

Parts - 3 years

Wear Items, such as pedals, seat, and brake pad - 1 year

Labor - 1 year

Stated warranty periods are from the date of original purchase. Warranty is valid only in Canada and the United States of America.

Limitations and Exclusions

This warranty only applies to the original owner. This warranty is expressly limited to the repair or replacement of a defective frame or defective part and is the sole remedy of the warranty. This warranty does not apply to any defects caused by normal wear and tear, negligence, misuse, accident, alteration, improper maintenance or discoloration/cosmetic damage of paint or plastic. WATERS FITNESS shall not be responsible for incidental or consequential damages. Any replacement part shall be warranted for the remainder of the original warranty term.

WATERS FITNESS expressly disclaims all other warranties, expressed or implied, in connection with the sale, service, or shipment of our products. This warranty gives you specific rights, and your rights may vary from state to state.

Important Information to Retain in your Records.

1) Copy of Sales Receipt

2) Model Name

3) Serial #

4) Date Purchased

Table of Contents

Warranty.....	4
Safety Instructions	6
Assembly.....	7-9
Installing the Front Foot	7
Installing the Rear Foot	7
Installing the Handlebar Assembly.....	8
Installing the Seat Assembly.....	8
Installing the Pedals	9
Installing the Water bottle Cage.....	9
Operational Instructions	10-12
Seat Adjustments.....	10
Handlebar Adjustments.....	10
Pedal Strap Adjustments	11
Resistance Control	11
Dismounting the Indoor Cycle	12
Preventative Maintenance	12
Warranty Registration	13

Safety Instructions

Important: Read all safety instructions before using the Indoor Cycle.

1. Keep children off the Indoor Cycle at all times.
2. Keep children and pets away from the Indoor Cycle while in use.
3. The maximum weight on the Indoor Cycle is 350 lbs.
4. Ensure all adjustment knobs (seat & handlebar) are properly set and allow for proper range of motion during exercise.
5. Keep hands or feet away from all moving parts, including the flywheel and drive system. Never attempt to turn the pedal cranks by hand.
6. The Indoor Cycle has a weighted flywheel with a fixed gear, which means that the pedals will continue to turn as long as the flywheel is still moving. To stop the unit quickly, push down on the resistance knob to stop the flywheel. Do not attempt to remove your feet from the pedals while they are in motion.
7. Always maintain control of the ride. Practice any technique at slower speeds before executing at faster speeds.
8. If you experience chest pains, feel faint, dizzy or have shortness of breath, stop exercising and immediately consult a physician.
9. Wear proper footwear when using the Indoor Cycle; never operate with bare feet.
10. Only use the Indoor Cycle on level, stable flooring.

Assembly

1) Install the Front Foot

Using the 5mm Allen key and a 13mm open end wrench, attach the front foot using the bolts, washers and nuts provided. The wheels on the foot should be facing forward.

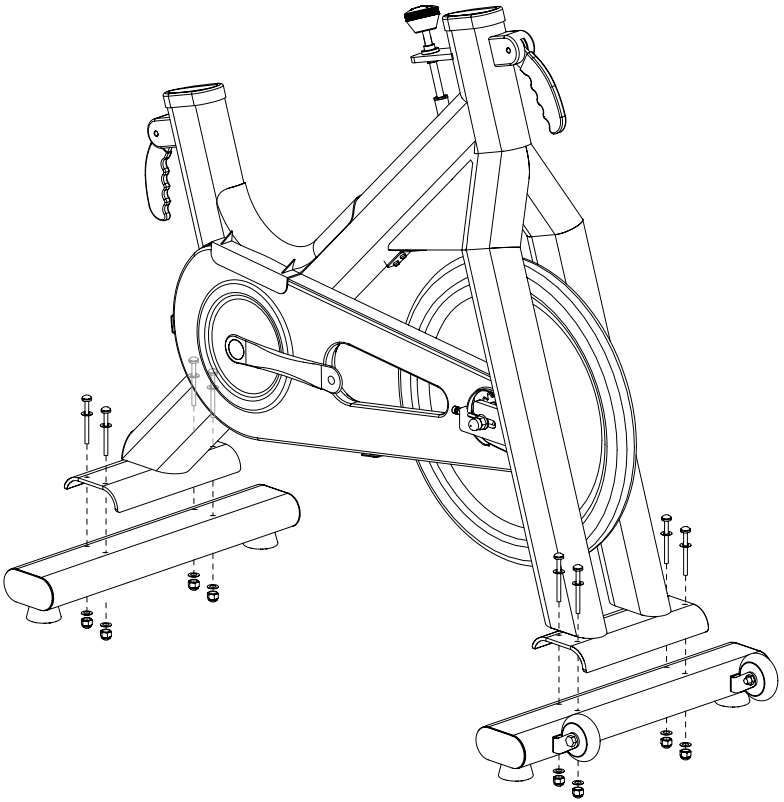

2) Install the Rear Foot

Using the 5mm Allen key and a 13mm open end wrench, attach the rear foot using the bolts, washers and nuts provided.

3) Installing the Handlebar Assembly

Tsunami Pro: Make sure the Quick Release handle is in the up position (loose) prior to installing the handlebar assembly.

Slide the handlebar post into the front frame opening; the handlebar should be facing forward. Make sure the handlebar post is into the frame deeper than the minimum insertion mark. Tighten the handlebar assembly into the frame by closing the Quick Release handle (push it down).

Tsunami Sport: Insure the adjustment pin is seated into a hole and tighten the adjustment knob clockwise when tightening the handlebar.

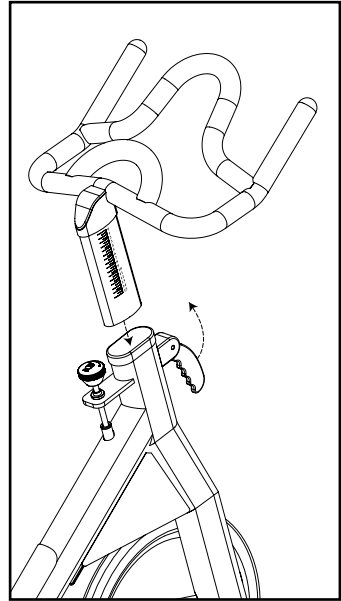

4) Installing the Seat Assembly

Tsunami Pro: Make sure the Quick Release handle is in the up position (loose) prior to installing the seat assembly.

Slide the seat post into the back frame opening; the seat should be facing forward. Make sure the seat post is into the frame deeper than the minimum insertion mark. Tighten the seat assembly into the frame by closing the Quick Release handle (push it down).

Tsunami Sport: Insure the adjustment pin is seated into a hole and tighten the adjustment knob clockwise when tightening the seat assembly.

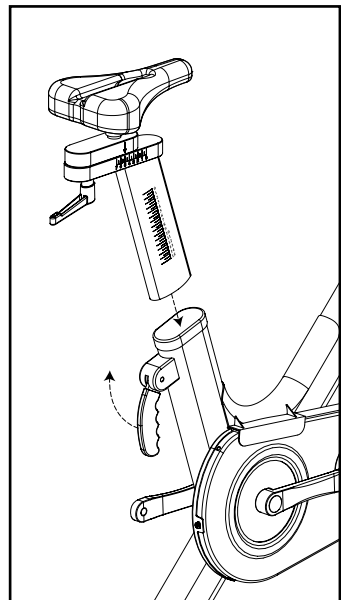

5) Installing The Pedals

Important: Each pedal is marked with either an “R” (right) or an “L” (left) on the pedal shaft. Installing the pedal on the wrong side of the bike may damage the pedals and/or the crank arms. An easy way to know if you are attaching the pedals properly is to always thread the pedals towards the front of the bike. Pedals are designed this way so they don't loosen during use. Be careful to align the treads properly to avoid damage.

Using the 15mm open end wrench, tighten the pedals firmly.

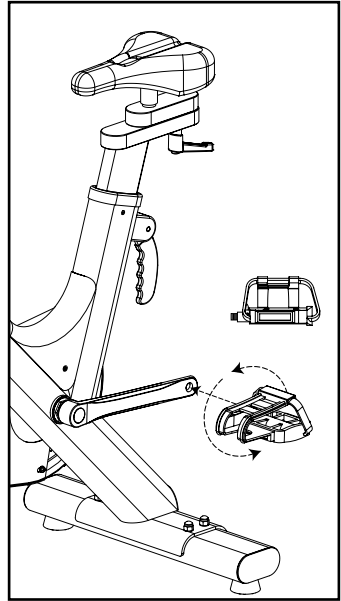

6) Installing The Water Bottle Cage

The water bottle screws are already attached to the frame. Simply remove them with a 4mm Allen key and reinstall them with a cage.

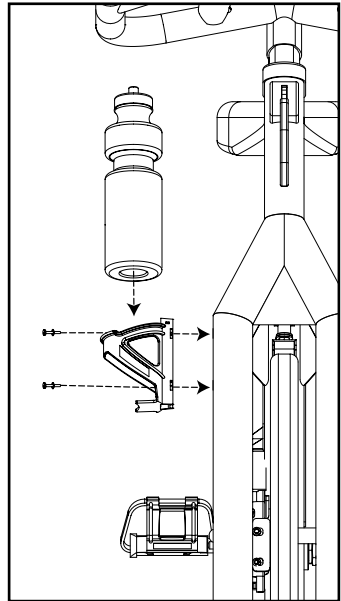

Operational Instructions

1) Seat Adjustments

The easiest way to start this adjustment is to stand next to the bike and raise the seat to hip height. Mount the bike and check to see if you have a slight bend in your knee when the pedal is in the 6 o'clock position. Once you have the correct height, it is time to review the fore/aft position of the seat. The proper fore/aft position is when your knee is over the pedal axle in the 3 o'clock pedal position. After you complete the fore/aft adjustment, you may need to review the seat height one more time to insure proper positioning.

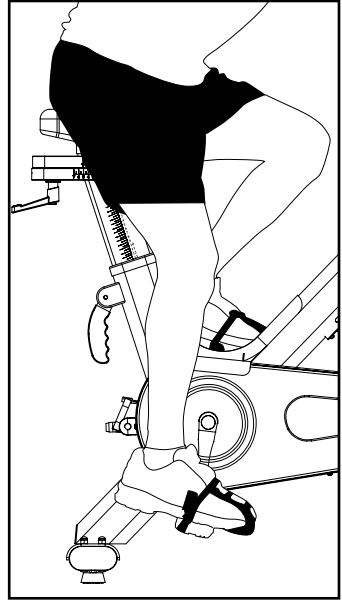

2) Handlebar Adjustments

Handlebar height is really a matter of preference. It is best to start with a height similar to the seat. If a more comfortable position is desired, move the handlebar higher to achieve a more upright position. Many experienced bike riders may prefer a lower handlebar setting which places them in a prone position similar to their road bike.

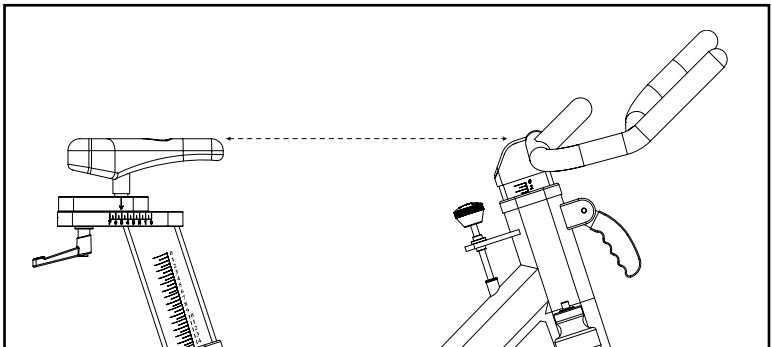

3) Pedal Strap Adjustments

The balls of your feet should be positioned over the axle of the pedal. Rotate the pedals until one of your feet is in the 12 o'clock position. Pull on the strap so it tightens the clip snugly against your shoe. Repeat this process with the other foot. To loosen the clip, simply push outward on the adjustment tab.

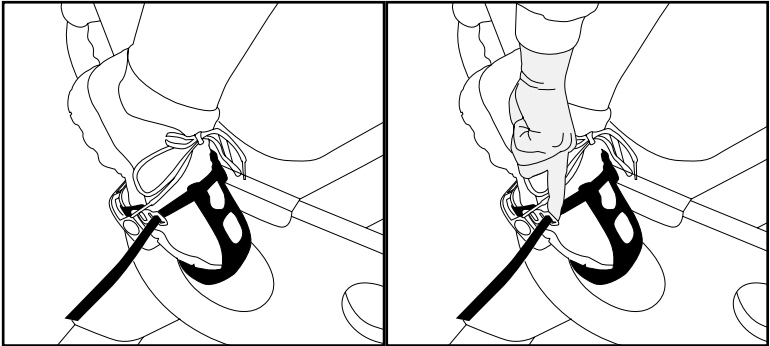

4) Resistance Control

Pedaling resistance is controlled by the resistance knob behind the handlebars. Resistance can be adjusted while riding by simply turning the knob. To increase resistance, turn the knob clockwise; to decrease resistance, turn the knob counter-clockwise. To quickly stop the flywheel, press down directly on the resistance knob.

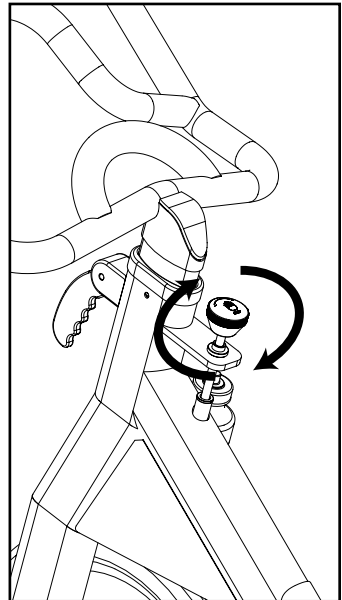

5) Dismounting the Cycle

This product has a weighted flywheel with a fixed gear, meaning the pedals will continue to turn as long as the flywheel is still moving. To stop the flywheel, push down on the resistance knob. Once the pedals have stopped moving, it is safe to dismount the cycle.

Important: Do not attempt to remove your feet from the pedals while they are in motion.

Preventative Maintenance

Daily - Wipe down the cycle at the end of each usage. This will keep the unit clean and prevent rust/corrosion. It is best to use a liquid non-abrasive cleaner. It is also best to remove the resistance tension from the flywheel after each usage by turning the resistance knob counter-clockwise.

Weekly - Inspect and tighten all bolts, assemblies and parts.

Monthly - Inspect frame for rust/corrosion and wear items for adjustment. Frame should receive a complete inspection including a tilt-up to view the bottom side of the Indoor Cycle. Remove any rust with a cloth or small brush. Wear items such as pedals, seat, and brake pad should be inspected for adjustment or replacement.

WATERS FITNESS Warranty Registration

Please complete and return this Warranty Registration Card within 30 days of receipt.

Last Name

First Name

Address

City

State

Country

Postal Code

Phone Number

Email Address

Date Purchased

Serial Number

Purchased From

City

State

Signature of Purchaser

Detach and mail to WATERS FITNESS.

Place
Stamp
Here

WATERS

the essence of health & fitness

WatersFitness, LLC 740 Pierce Street, Waterloo WI 53594

WATERS

the essence of health & fitness

Waters Fitness, LLC 740 Pierce St., Waterloo WI 53594
888.850.9973 f:262.923.1000 www.watersfitness.com